

Produktinformation
Kühlmittelführung
Product Information
coolant routing

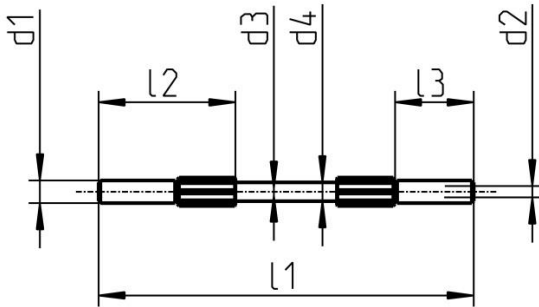

Flex-Leitungen

Flexible tubes



Bestellnummer Part number	l1	l2	l3	d1	d2	d3	d4	max. Druck [bar] max. pressure [bar]
21-1109	100	36,5	21	6	3	2	5	400
21-1111	150	36,5	21	6	3	2	5	400
21-1112	200	36,5	21	6	3	2	5	400
21-1113	250	36,5	21	6	3	2	5	400
21-1114	300	36,5	21	6	3	2	5	400
21-1115	400	36,5	21	6	3	2	5	400
21-1116	500	36,5	21	6	3	2	5	400
21-1159	200	57	20	6	3	4	8,5	340
21-1160	250	57	20	6	3	4	8,5	340
21-1161	300	57	20	6	3	4	8,5	340
21-1162	400	57	20	6	3	4	8,5	340
21-1163	500	57	20	6	3	4	8,5	340

Abmessungen in mm
Dimensions in mm

Hinweis / Note:

Weitere Längen auf Anfrage

d3 = Innendurchmesser der Leitung

other lengths on request

d3 = internal diameter of the tube

Kühlmittelanschlüsse

Coolant connections

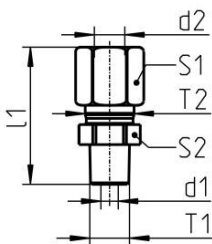

A: Gerade / straight

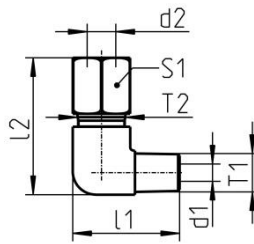

B: 90° Winkel / 90° angle

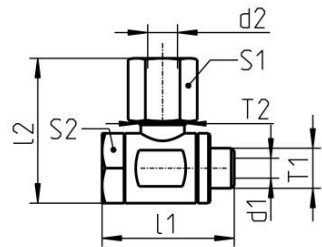

C: 360° schwenkbar / 360° swiveling



Ausführung Design	Bestellnummer Part number	l1	l2	d1	d2	T1	T2	S1	S2
A	004.00.14	33,7	-	4	6	G1/8" keg.	M12x1,5	SW14	SW14
A	004.00.19	28	-	3,5	6	M8x1 keg.	M10x1	SW12	SW11
A	004.00.36	27,5	-	2	4	M6x1 keg.	M8x1	SW10	SW9
A	004.00.15	41,5	-	7	10	G1/4" keg.	M16	SW19	SW17
B	004.00.22	22,4	28,2	3,6	6	M8x1 keg.	M10x1	SW12	-
B	004.00.33	26,6	35,6	4,5	6	G1/8" keg.	M12x1,5	SW14	-
B	004.00.34	38,9	33,6	7	10	G1/4" keg.	M16	SW19	-
B	004.00.37	22,3	27,6	2	4	M6x1 keg.	M8x1	SW10	-
C	004.00.61	26,5	29	4	6	M8x1	M12x1,5	SW12	SW14
C	004.00.16	26,5	29	4	6	G1/8"	M12x1,5	SW12	SW14
C	004.00.47	36,7	43,2	6,5	6	G1/4"	M14	SW17	SW19
C	004.00.18	36,7	43,2	6,5	10	G1/4"	M16	SW19	SW19

Abmessungen in mm
Dimensions in mm

Hinweis / Note:

Druckbeständig bis 100bar - weitere Größen und Ausführungen auf Anfrage
d2 = Klemmdurchmesser für Flex-Leitungen // T1 = keg. = Kegelgewinde
pressure up to 100 bar - other sizes and designs on request
d2 = clamp diameter for flexible tubes // T1 = keg. = tapered thread

Verschlussstopfen Sealing plug

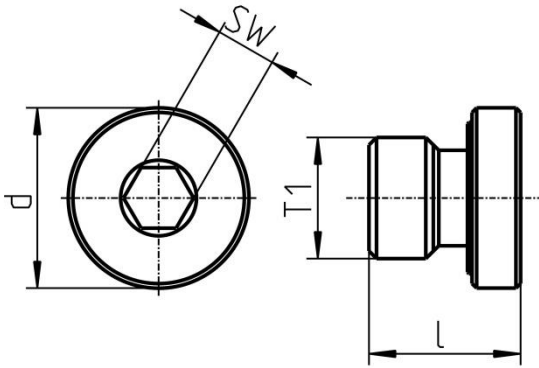

Bestellnummer Part number	l	d	T1	SW
004.00.21	10	12	M8x1	4
004.00.26	12	14	G1/8"	5
004.00.27	12	20	G1/4"	6

Abmessungen in mm
Dimensions in mm

Hinweis / Note:

Weitere Größen und Ausführungen auf Anfrage
other sizes and designs on request

Schnellkupplungen

Quick couplings

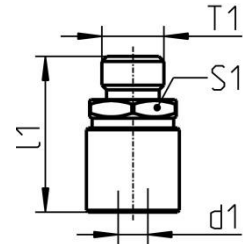

A Kupplung, weiblich /
coupling, female

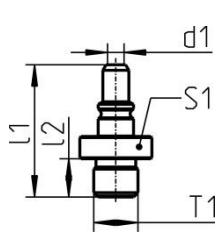

B

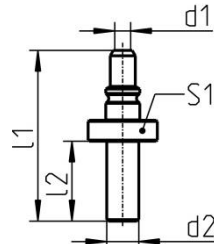

C

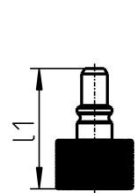

D



Kupplung, männlich / couplings, male

Ausführung Design	Bestellnummer Part number	l1	l2	d1	d2	T1	S1
A	Kupplung / couplings						
A *1 *2	004.00.49	25	-	4,9	-	M10x1	SW14
A	004.00.71	25	-	4,9	-	G1/8"	SW14
A	004.00.73	25	-	4,9	-	M8x1	SW14
B	Schraubanschluss / screw connection						
B	004.00.56	24,25	7	3	-	M8x1	SW13
B	004.00.57	24,25	7	3	-	G1/8"	SW13
B	004.00.58	24,25	7	3	-	G1/4"	SW17
B *1	004.00.63	24,25	7	3	-	M10x1	SW13
C	Klemmverbindung / clamp connection						
C	004.00.59	32	15	3	6	-	SW13
D	Verschlussstopfen / Sealing plug						
D	004.00.66	22	-	-	-	-	-

Abmessungen in mm
Dimensions in mm

Hinweis / Note:

Druckbeständig bis 100bar - weitere Größen und Ausführungen der männlichen Kupplungen auf Anfrage

*1 = Klemmmöglichkeit für Flex-Leitungen gegeben

*2 = inkl. Überwurfmutter und Schneidring

pressure up to 100 bar - other sizes and designs of the male couplings on request

*1 = terminal opportunity for flex lines given

*2 = incl. union nut and olive

Verteilerleisten

Distributor blocks

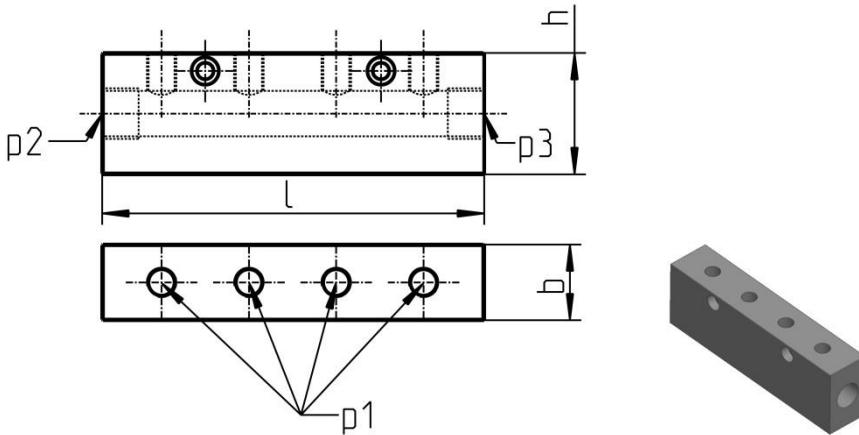

Bestellnummer Part number	l	b	h	p1		p2	p3
				Anzahl numbers	Art type		
21-4207	66	25	40	2	M8x1	G3/4"	G3/4"
21-4208	66	25	40	2	G1/8"	G3/4"	G3/4"
21-4209	96	25	40	3	M8x1	G3/4"	G3/4"
21-4210	96	25	40	3	G1/8"	G3/4"	G3/4"
21-4211	126	25	40	4	M8x1	G3/4"	G3/4"
21-4212	126	25	40	4	G1/8"	G3/4"	G3/4"
21-4213	186	25	40	6	M8x1	G3/4"	G3/4"
21-4214	186	25	40	6	G1/8"	G3/4"	G3/4"

Abmessungen in mm
Dimensions in mm

Hinweis / Note:

Weitere Größen und Ausführungen auf Anfrage
other sizes and designs on request

Verbindungsbeispiel Connection example

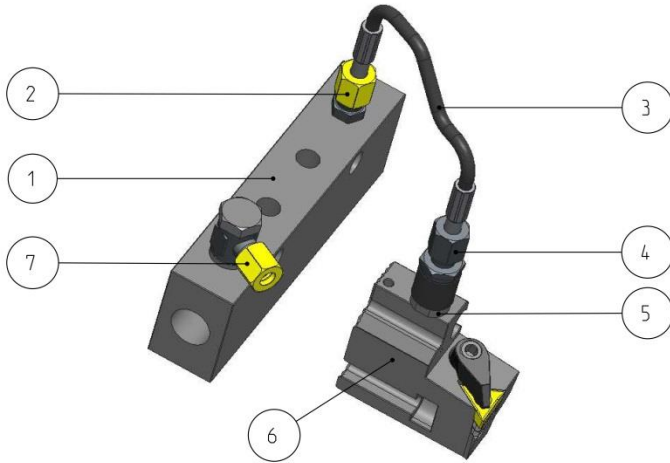

Pos.	Bauteil part	Bestellnummer Part number	Broschürenseite booklets page
1	Verteilerleiste distributor block	21-4211	5
2	Kühlmittelanschluss coolant connection	004.00.19	2
3	Flex-Leitung flexible tube	21-1114	1
4	Schnellkupplung, weiblich quick coupling, female	004.00.49	4
5	Kupplung, männlich coupling, male	004.00.63	4
6	Rückseitenhalter, höhenverstellbar back holder, adjustable	R84.TN16.IK	-
7	Kühlmittelanschluss coolant connection	004.00.61	2

Hinweis / Note:

Bei Fragen und Verbindungsproblemen, beraten wir Sie gerne
For questions and connectivity problems, we advise you

**Das GRAF-Werkzeugprogramm mit Innenkühlung
Fordern Sie die neusten Unterlagen an!**

The GRAF-Tool program with interior cooling.
Ask for the latest documents!

