

Firma
company

Kunden Nr.
customer Nr.

Datum
date

PLZ, Ort, Straße, Nr.
ZIP, town, street, No.

Gewünschtes Lieferdatum
desired delivery date

Kontaktperson
contact person

E-Mail

Tel. Nr.

Menge/Stück
amount/pcs

Material raw material

P
H
K
M
N
S

Härte
hardness

Bezeichnung
ISO number

Bearbeitung processing

Schruppen
Roughing

Schlichten
Finishing

Profilfräsen
Profile milling

Trochoidalfräsen
trochoidal milling

Umfangfräsen
side milling

3D Fräsen
3D milling

Nutfräsen
slotting

Planfräsen
face milling

Trochoidalfräsen
trochoidal milling

Umfangfräsen
side milling

Kühlung cooling

Innenkühlung
internal cooling

Emulsion
emulsion

Öl
oil

Luft
air

andere
others

ohne Kühlung
without cooling

Bisheriges Werkzeug previously used tool

Hersteller/Bezeichnung
producer/name

Standmenge
life quantity

ist
actual

soll
target

Optimierung
optimisation

Schaftform shank type

DIN 6535
DIN 6535

HA
HA 

HB
HB 

HE
HE 

Ausführung Ecke corner design

Vollradius
full radius 

Eckenfase
corner chamfer 

Eckenradius
corner radius 

ähnlich Katalogwerkzeug, Artikel Nr.
similar to standard catalogue tool, item number

Skizze draft

Anzahl Zähne 
number of teeth

Zentrumsschnitt
centre cutting

Beschichtung
coating

Lasersignatur
laser marking

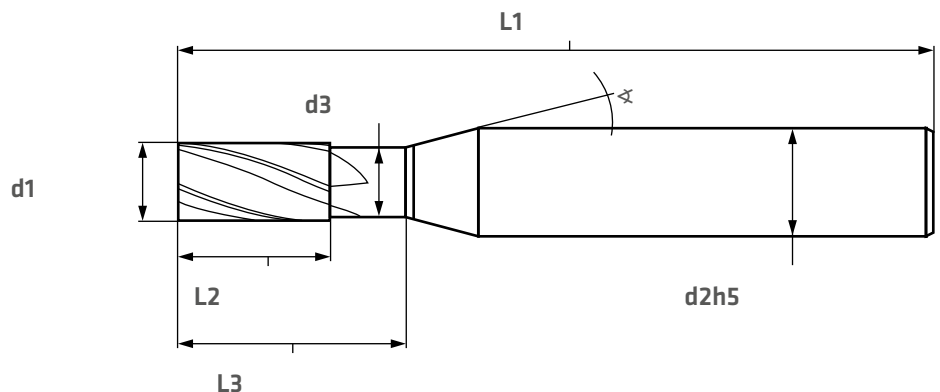

Details
details